

SANDBACH TOWN COUNCIL

Planning & Consultation Committee

This meeting will be clerked by Mike Wellings. Please ensure that all apologies are made directly to the clerk of the meeting no later than 6pm on the day of the meeting.

Agenda for the meeting to be held on Monday 11 January 2021 at 7.00pm on the Zooms Meeting Platform. The code for entry to this meeting is:

856 2849 6828. Virtual Meeting guidance for Members of the Public can be found on the Meetings Page of the Sandbach Town Council Website.

1. APOLOGIES FOR ABSENCE

2. DECLARATIONS OF INTEREST

To provide an opportunity for Members and Officers to declare any disclosable pecuniary and non-pecuniary interests in any item on the agenda.

The Chairman of the meeting will adjourn the meeting to allow questions from members of the public. After the questions, the Chairman will reconvene the Planning Committee Meeting.

3. TO APPROVE THE MINUTES OF THE PLANNING AND CONSULTATION COMMITTEE MEETING HELD ON WEDNESDAY 9 DECEMBER 2020.

4. OBSERVATIONS ON PLANNING APPLICATIONS

Submitted WE 15.12.20 response to Cheshire East by 28.01.21

20/5466C Land Bounded by Old Mill Road and M6 Northbound Slip Road, Sandbach
Full Planning Permission for the construction of Drive Through Coffee Unit, Drive Through Restaurant Unit, Electric Vehicle charging point, Commercial Park Entrance and associated Parking/Landscape. Outline planning permission, for development comprising of a public house and restaurant, 63 bedroom hotel, offices with associated parking/landscape.

Submitted WE 22.12.20 response to Cheshire East by 13.01.21

20/5683C 61 Fields Drive, Sandbach, CW11 1YB

Proposed single storey rear extension, two storey side extension, new porch and single storey front extension.

20/3992C 1 Pickmere Close, Sandbach, CW11 1TR

Change of use of land.

- 20/5715C Land Off, Moss Lane, Sandbach
Variation of condition 2 on application 17/3693C.
- 20/5584C 123 Middlewich Road, Sandbach, CW11 1FH
Reconstruction of existing dwelling with 2 storey side and rear extensions to original plan area.
- 20/5792C 10 Taxmere Close, Sandbach, CW11 1WT
Proposed detached garage and two storey extension.
- 20/5776C 94 Heath Road, Sandbach, CW11 2LE
Construction of new dwelling adjacent to existing dwelling at 94 Heath Road.

Submitted WE 29.12.20 response to Cheshire East by 19.01.21

At time of posting, further applications were not available.

A supplementary list will be issued on the day of the meeting and an updated agenda posted on to Sandbach Town Council's website.

5. CONSULTATIONS

5.1 Cheshire East Draft Tenancy Strategy (Deferred from last meeting of the Committee)

Information attached on the consultation of the Cheshire East Draft Tenancy Strategy, which seeks to update the 2012 Tenancy Strategy. Deadline for comments is 18th January 2021.

5.2 Cheshire East Council Transport and Parking Consultations

Information on the consultations is attached and available at www.cheshireeast.gov.uk/LocalTransportEngagement . The deadline for comment is 31 January 2021.

5.3 ChALC Speeding Questionnaire

The Questionnaire and supporting information is attached with the deadline for reply being the 31 January 2021.

6. CORRESPONDENCE

6.1 Cheshire East Council

Email dated 11 December in reply to comments made by the Committee in regards to the revocation of AQ Management Areas.

6.2 A Resident

Email dated 18 December concerning the Old Middlewich Road Cycle Lane.

6.3 Cycling UK

Email dated 3 January concerning the Local Transport Delivery Plan.

6.4 Cycling UK

Email dated 3 January concerning application 20/5466C – Capricorn Park.

7. DATE/TIME AND PLACE OF NEXT MEETING

The next Planning Committee meeting will take place on Monday, 25 January 2021 at 7pm via Zoom. The Room number will be circulated prior to the meeting.

Please note that this meeting will be recorded and the audio recording made available to the public within 5 working days of the meeting.

BLANK

PAGE

- What measurements of cycling activity were taken on this stretch of road prior to installation.
- What cost benefit analysis was done to ensure added value?
- What uplift in cycling was considered a success?
- What ongoing monitoring is being done?
- Exits onto a blind junction at roundabout and makes road too narrow for HGVS and emergency vehicles to pass.
- Why is it contraflow?
- A lot of parking spaces has been lost which is useful for local residents.
- What has been achieved by introducing the cycle lane – it is already a quiet road. Many cyclists on social media say that they won't use it.
- Aesthetically it looks a mess and a lot of tax payer money appears to have been wasted if bollards are now to be lifted.

The Chair noted that most of these points had been addressed in Cllr L Crane's email.

Another resident agreed with the previous speakers comments and noted the money could have been better spent elsewhere. He also highlighted that the cycle lane is not helpful for disabled residents.

The Chair pointed out that the Town Council is only a consultee, the actual work is carried out by Cheshire East Council using funding from central government that had to be spent in a short period of time.

A further resident raised the issue of the 20mph speed limits in and around Sandbach. Questioned why speed limits had been put in around Sandbach whilst having missed some of the most dangerous areas in the process, for example, Ettiley Heath. Cllr Hovey confirmed that it was only a Town Centre scheme, but suggested writing to Cheshire East Highways highlighting the need for a 20mph speed limit on Abbey Road.

Cllr Corcoran commented on the Old Middlewich Road scheme and said he had mixed views about the wands. Whilst they cause issues for drivers, they do make cyclists feel safe. He agrees that costs have been high for the scheme, although this is in part due to a contract CEC have entered into with Ringway Jacobs.

Cllr Corcoran also noted the Parking consultation item and suggested the Parking Strategy put together in 2009 by the Town Council either be put forward as a response or form the basis of a response.

As there were no more questions, the meeting was immediately reconvened.

3. TO APPROVE THE MINUTES OF THE PLANNING AND CONSULTATION COMMITTEE MEETING HELD ON MONDAY 23 NOVEMBER 2020.

Councillor Flavell noted that she had called in 25 Teddy Gray Avenue following the last meeting in her capacity as CEC Ward Cllr.

Resolved: That the minutes be approved as a true record of the meeting.

4. OBSERVATIONS ON PLANNING APPLICATIONS

Submitted WE 27.11.20 response to Cheshire East by 15.12.20

20/5088C 124 Heath Road, Sandbach, CW11 2LE

New side extension.

Resolved: No objection.

20/5235C Blackacres Cottage, 158 Middlewich Road, Sandbach, CW11 1FH

Alterations and extensions to existing semi-detached dwelling.

Resolved: No objection.

Submitted WE 04.12.20 response to Cheshire East by 25.12.20

No applications received.

Submitted WE 11.12.20 response to Cheshire East by 30.12.20

20/5327C 123 Middlewich Road, Sandbach, CW11 1FH

Front boundary wall and gates.

Resolved: Members **OBJECT** to this application due to the gate being situated up against the edge of the pavement. This means cars would have to stop in the narrow highway when waiting for the gates to open/close to gain entry/leave the site. Members recommend that the gate is set back into the site to give vehicles space to stop safely.

20/5083C 42 Coleridge Close, Sandbach, CW11 3NN

Two storey side extension.

Resolved: No objection.

20/5454C 9 Tatton Drive, Sandbach, CW11 1DR

Alterations and extensions to existing dwelling.

Resolved: No objection.

5. ACTIVE TRAVEL CONSULTATION – 2 WAY CYCLE LANE ON MIDDLEWICH ROAD

Item requested at last meeting of the Planning and Consultation Committee.

[Attached: Correspondence received from Cycling UK]

Lead: Meeting Chair

Action: To ascertain if the Committee wishes to make any comment to CEC on this issue, and if so, what comments should be made.

Members had several strong concerns regarding the 2 Way Cycle Lane, including the impact on business along that stretch who have subsequently complained and the fact that the cycle lane is too wide and not helpful in its current guise. Furthermore, it was noted that the cycle lane does not join up to anything and is taking away parking from an area of town where it is desperately needed. In addition to this, elderly residents in Sandbach must use private vehicles due to poor Transport links in the area. It was suggested that some of the bays should be market as disabled to help with this issue.

Cllr Jack proposed that Sandbach Town Council object to the installation of this project with it being scrapped immediately. Furthermore the disabled bays,

parking bays and original advisory cycle lane on the site should be reinstated. The proposal was not seconded.

Cllr Flavell proposed that the Committee accept the amendments to turn the cycle lane into a single lane, which have been suggested by Cllr L Crane, but also to suggest that some of the bays on the opposite side of the road should be made disabled. The proposal was seconded by Cllr S Crane. Cllr Jack requested a named vote.

Members voted as follows:

4 In Favour: Cllrs S Crane, Flavell, Hovey and Price Jones.

3 Against: Cllrs Jack, Merry and Muldoon.

1 Abstention: Cllr Broad.

A majority voted in favour and the motion was carried.

Resolved: That the Committee accept the amendments to turn the cycle lane into a single lane, which have been suggested by Cllr L Crane, but also to suggest that some of the bays on the opposite side of the road should be made into disabled spaces.

6. CONSULTATIONS

6.1 Cheshire East Planning Policy Documents Consultation (Deferred from last meeting of the Committee)

Information in attachment on three documents published by CEC for Consultation:

- *Revised Publication Draft Site Allocation s and Development Policies Document (SADPD) – Deadline for comment – 5pm Monday 7th December 2020.*
- *Draft Houses in Multiple Occupation Supplementary Planning Document (HMO SPD). – Deadline for comment – 5pm Monday 7th December 2020.*
- *Article 4(1) Directions to withdraw permitted development rights for the change of use of dwellings to small houses in multiple occupation in parts of Crewe. – Deadline for comment – 5pm Monday 30th November 2020.*

Resolved: Cllr Hovey is to make notes and circulate comments to the Committee on the 1st part of the consultation and Cllr Merry on the 2nd and 3rd parts prior to the submission deadline.

6.2 Cheshire East Draft Tenancy Strategy (Deferred from last meeting of the Committee)

Information attached on the consultation of the Cheshire East Draft Tenancy Strategy, which seeks to update the 2012 Tenancy Strategy. Deadline for comments is 18th January 2021.

It was agreed that the item is deferred until the next meeting of the Committee and Cllr Hovey produces notes for circulation.

6.3 Revocation of Air Quality Management Areas (Deferred from last meeting of the Committee)

Information attached and available at:

https://www.cheshireeast.gov.uk/environment/environmental_health/local_air_quality/local_air_quality.aspx concerning the proposed revocation of 7 AQMAs across the Borough, with one being in Sandbach – Middlewich Road. The deadline for comment is 5pm on the 11th December 2020.

Resolved: That Members **OBJECT** to the revocation of the AQMA on Middlewich Road, Sandbach. Monitoring should be continued with pollution reduction measures implemented as planned.

Measure GN9 references the use of NOx busting paint “on surfaces within the city especially within AQMAs”. Members are not aware that Cheshire East is or contains a city, but would be interesting to have tried some of this paint in Sandbach.

The two AQMAs for Sandbach are Middlewich Road and around J17, neither of the measures proposed in 2018 SAND1 and SAND2 reviewing traffic flows and priorities at the Ashfields junction and a vehicle weight restriction on the road appear in the report ever to have been “planned,” “implemented” or “progressed”, with no “estimated completion date”.

6.4 Cheshire East Council Transport and Parking Consultations

Information on the consultations is attached and available at www.cheshireeast.gov.uk/LocalTransportEngagement . The deadline for comment is 31 January 2021.

Members noted that the Sandbach Parking Strategy from 2009 (Formed in response to the consultation on Car Parking Charges at the time) is a useful document, it cannot be depending on to help provide a response to this consultation and would need to be brought up to date. Furthermore, it was queried why there is not a “no charge” option contained in the consultation.

It was agreed that the item is deferred until the next meeting of the Committee and Cllr Price Jones produces notes for circulation.

6.5 Marton Neighbourhood Development Plan (Modification) Regulation 16 Consultation

Information on the consultation is attached and available at: <https://www.cheshireeast.gov.uk/planning/neighbourhood-plans/neighbourhood-plans-g-m/marton-neighbourhood-plan.aspx> . The closing date for comments is 7pm on 6 January 2021.

This item was noted.

6.6 Cheshire East Council Pre-Budget Consultation for 2021-2025

Information on this consultation is attached and available at https://www.cheshireeast.gov.uk/council_and_democracy/council_information/consultations/budget-engagement-2021.aspx . The deadline for comment is 8th January 2021.

This item was noted. As there is not another Planning & Consultation Committee meeting before the deadline, the Chair of the meeting encouraged Members to submit their own comments, if they wished to.

7. CORRESPONDENCE

7.1 Cycling UK

Email dated 30 November with comments in relation to 20/4673C Brookhouse Road.

Matthias Bunte was thanked for his correspondence.

7.2 A Sandbach Resident

Email received on the 2nd December concerning the Two Way cycle lane on Middlewich Road.

Members noted the correspondence.

7.3 A Sandbach Resident

Email received on the 7th December outlining objections to the revocation of the Middlewich Road AQMA.

Members noted the correspondence

8. DATE/TIME AND PLACE OF NEXT MEETING

The next Planning Committee meeting will take place on Monday, 11 January 2021 at 7pm via Zoom. The Room number will be circulated prior to the meeting.

The Chair of the Meeting thanked everyone for attending, and as this is the last Town Council Committee Meeting of the year, wished everyone a Merry Christmas and a return to a hopefully normal New Year.

Meeting closed 8.16pm

Cllr R Hovey

MW

Sent on behalf of Karen Carsberg, Head of Housing

Dear colleague.

I am writing to advise you that Cheshire East Council has produced a draft new Tenancy Strategy, which is an update of the 2012 Tenancy Strategy. Approval has been given by Cheshire East Cabinet to commence the consultation process.

The new Strategy has been developed following engagement with Registered Housing Providers and outlines Cheshire East Council's preference for Registered Housing Providers operating within Cheshire East to use long - term tenancies, with the use of shorter, fixed - term tenancies **as the exception**, as part of a neighbourhood regeneration / asset management project, for example. Introductory or Starter tenancies which end successfully should normally be converted into Lifetime tenancies.

Cheshire East Council is carrying out a 12 week consultation on the draft Tenancy Strategy between **26th October 2020 and 18th January 2021**.

The consultation page and draft Tenancy Strategy may be found here:

<https://surveys.cheshireeast.gov.uk/s/LAP1F0/>

The Council is seeking the views of Registered Housing Providers, present and future social housing applicants on Cheshire HomeChoice, residents, Elected Members, and any other interested parties.

Your comments will be much appreciated.

If you have any questions please contact Chris Hutton, who will be happy to help:

Christopher Hutton
Senior Policy Officer
Cheshire East Council
Tel: 01270 685642
e-mail: Christopher.Hutton@cheshireeast.gov.uk

Best wishes.

Yours sincerely,

Karen Carsberg

Head of Housing

BLANK

PAGE

News Release



23 November 2020

Cheshire East Council launches consultations on transport and parking

Cheshire East Council has launched public consultations on local transport and parking plans across the borough.

The consultations, which begin today and end on 31 January 2021, will seek to engage with communities, towns, elected members and stakeholders.

The results of this exercise will inform the future direction of how to improve transport, walking and cycling in our towns. It will also inform proposals, which would be subject to further consultation, regarding changes to parking provision and potential changes to car parking charges in the borough.

The local transport plan consultations are based around the following themes:

- **Accessibility for all** – considering all travel needs;
- **Sustainability** – improving walking, cycling and public transport;
- **Quality of the public realm** – managing traffic to support town centres and the visitor economy;
- **Better neighbourhoods** – improving amenities where people live; and
- **Connectivity** – the strategic links needed to access work, education and essential services, such as hospitals.

Councillor Craig Browne, deputy leader of Cheshire East Council, said: “This consultation is an opportunity for us to work together and get the right blend of local transport provision in the right places.

“Alongside these plans, we are also developing town centre vitality plans for our key service centres, helping us to better understand and respond to local needs.

“We must also consider the potential longer-term impacts of Covid-19. This may include using our spaces differently to enable social distancing, more reliance on active travel and public transport, as well as increased home working.”

The car parking consultation looks at:

- The role of parking in accessing town centres (current and future);
- The level of parking charges in Cheshire East and scope for harmonisation;
- On-street parking restrictions; and
- Improving parking services.

Councillor Laura Crane, Cheshire East Council cabinet members for highways and waste, said: "The local transport plan sets out a need for greater harmonisation of parking arrangements across Cheshire East, during the period 2020 to 2025.

"The parking consultation, alongside the development of town vitality plans, will engage many stakeholders to ensure we have a broad strategy moving forward, taking into account the economic, environmental and community elements that car parking brings."

The responses to the consultations will be used to shape policies and proposals going forward.

To find out more and take part in the consultations visit the council's web page at: www.cheshireeast.gov.uk/LocalTransportEngagement

ENDS

Photo captions:

Councillor Craig Browne, deputy leader of Cheshire East Council

Councillor Laura Crane, Cheshire East Council member for highways and waste

Transport image

Senior Media Relations Officer: Tim Oliver

Direct line: 01270 686591

Mobile: 07879 117185

Email: tim.oliver@cheshireeast.gov.uk

IS VEHICLES SPEEDING A HIGH PRIORITY ISSUE IN YOUR TOWN/PARISH?

5.3

We know that for some Towns and Parishes in Cheshire speeding vehicles are regarded as an important issue which they would like to see Cheshire Constabulary and the Principal Councils afford a higher priority in partnership with them. We want to understand how widespread this community concern is, and if it is, to ask Cheshire Constabulary and the Principal Councils in turn to elevate it in their list of priorities for the next financial year. Would you please complete this simple questionnaire and return it to ChALC by the end of January 2021. We will of course let you know the results of this survey.

Many thanks for your cooperation in this matter.

NAME OF TOWN OR PARISH COUNCIL:			
SPEEDING IS THE TOP ISSUE FOR OUR TOWN/PARISH	SPEEDING IS NOT THE TOP ISSUE FOR US BUT IS ONE OF OUR TOP 3 ISSUES	SPEEDING IS NOT IN OUR TOP 3 ISSUES BUT IS ONE OF OUR TOP 5 ISSUES	SPEEDING IS NOT ONE OF OUR TOP 5 ISSUES
<i>Please tick one of the boxes above</i>			
If speeding is NOT one of your top issues please set out briefly here what is:			

*Councillor Steve Jones
ChALC Executive Board Member*

BLANK

PAGE

6.1

Dear Sandbach Town Council

Thank you for your email and I note the contents.

If I may I would just like to address some of the concerns you have raised.

We would continue to monitor within the area, we are not removing all of the monitoring tubes, there will be a single diffusion tube at the location that is currently providing us with the highest NO₂ reading. Tube locations are reviewed regularly to ensure they are placed in appropriate locations.

Even if the AQMA is revoked, the actions associated with it will be taken forward as we are obligated to ensure they are. Indeed a review was conducted into the traffic light phasing of the lights on the junction with Ashfields Way (SAND 1) and the outcome of this will be followed through with even if the AQMA is revoked. It is a view of ours that we don't stop trying to improve the air quality in an area just because the concentrations have fallen back below the objectives. There is no guarantee that SAND 2 will be implemented as it may be found that a weight restriction is not feasible for Middlewich Road for all manner of reasons. From initial discussions with Highway colleagues, weight limits do not apply to delivery vehicles in the area, so we would need evidence that there was a large amount of through traffic over 7.5tonnes, as otherwise the weight limit would have no impact.

In terms of GN9 and NO_x busting paint, as we reported in our [2020 Annual Status Report](#), this has been put on hold whilst we are awaiting the outcome of further research into the possible impacts of using the paint. You can also see from the same report on page 26 we give an update on the actions SAND1 and SAND2.

I hope this goes some way to alleviate your concerns.

Many thanks

Sarah Allwood BSc (Hons), MSc, Dip Acoustics, MCIEH, AMIOA
Senior Environmental Health Officer

BLANK

PAGE

Subject: Old Middlewich Road

Dear Ann,

Could this please be included in the notes for the next Planning Meeting?

On reading the Sandbach Chronicle report on the Planning meeting on 9th December, one of the objections to the cycle lane was that the new cycle lane "did not join up with anything." Whilst the debate has been had, I think it would be helpful just to clarify this. Old Middlewich Road connects Hightown, Sandbach town centre, and, going further, Sandbach Heath to Ashfields PCT, by way of the pedestrian crossing, which means walking the bike across Middlewich Road, which is no great inconvenience. This is my normal route to Ashfields/Aldi and I regularly use it, it is far safer than cycling round the Crewe Road roundabout. I believe that the cycle lane is not aimed at "cyclists" per se (lycra and £1,000 racing bikes), but at people wearing normal clothes who use their bikes as a mode of transport, or are on the verge of doing so. This email is not aimed at the pros and cons of the cycle lane, but to point out that Old Middlewich Road is indeed an important connecting route when travelling to Ashfields. A minor point, perhaps, but such misconceptions could affect important decisions. There will be further debates, no doubt, on further infrastructure changes aimed at making people feel safer on their bikes, and my concern is that decisions could be made based on just this sort of misconception.

Regards

BLANK

PAGE

Dear Mike,

A happy new year to you. I've sent the below as a response to the Local Transport Delivery Plan for Sandbach, specifically dealing with shared footways for pedestrians and cyclists. Should the consultation be an agenda item for the 11th then I would like to speak. If not then feel free to share with members as you see appropriate.

I am pleased that the consultation mentions several items from the Sandbach town cycling plan. However, for completeness I've added another 22 to my submission, as per attachment, where I felt they met the relevant objective. Again, please feel free to distribute to members of the Committee

Regards

Matthias Bunte

Cycling UK

Local Transport Delivery Plans and town cycling plan for Sandbach

Objective 1: Improving transport access to and within Sandbach to support a thriving market town

Are there any other options under this objective that we could look into that have not been identified?

Sandbach town cycling plan:

Item 20: Mill Hill Lane to High Street, Sandbach FP 21, to provide a connection to the town centre via quiet roads

- * upgrade for cycle use
- * surfacing between Mill Hill Lane and Coronation Crescent and modification to bollards
- * surfacing around Price Drive
- * converting pedestrian crossing at Old Mill Road to Toucan
- * modification to barrier either side of Old Mill Road (Flat Lane)

Objective 2: Improving transport connections between the town centre and Sandbach train station

6. Are there any other options under this objective that we could look into that have not been identified?

Sandbach town cycling plan:

Item 4: (old part of) Moston Road to Moss Lane:

6.3

- * route through concrete blocks

- * short cycle track across grass verge

Item 4a: Elworth, Foundry Lane/Clifton Rd to Station Rd; FP 46: new bridge as part of HS2

- * upgrade FP for cycle use

- * potential new bridge of adequate width, lit, smooth corners

Item 5: Elworth, Elton Crossings Road, crossing Salt Line Way to (the old part of) Moston Road

- * crossing for cyclists, i.e. roped kerbs in 'desire line'; removal/realignment of bollards

Item 7: Elworth, Dean Close to Vicarage Lane

- * upgrade for cycle use

Not mentioned on the Sandbach town cycling plan: junction of Station road with Moss Lane: * reduce speed of cars and especially lorries making lh turn from Moss Lane on to Station Road

Objective 3: Supporting access from rural communities around Sandbach to key services and employment

8. Are there any other options under this objective that we could look into that have not been identified?

Sandbach town cycling plan:

Item 3: Elworth, Marsh Green Road to Bradwall, Wood Lane, (Sandbach FP 36/Bradwall FP 3)

- * upgrade for cycle use,

- * surfacing, potentially small bridge in the middle to cross brook

item 14: Sandbach and Wheelock, Crewe Road

- * continuous cycle lane on both sides of road

- * at "pinch points" remove centre white line, signing indicating traffic priority from one direction and give way for the other direction

Item 16: Sandbach, Offley Road to Bradwall Road, Sandbach FP 6, via Sandbach Rugby Union Club

- * upgrade for cycle use,

6.3

- * partly surfacing

- * seeking connection through Rugby Club

Item 33: FPs at Sandbach Heath, Betchton Heath to Arclid/A50 for connection to employment sites at Arclid

- * upgrade for cycle use for part of the route

- * surfacing

Item 34: Sandbach Service Station (southbound), Betchton FP7, access for staff working at the service station

- * upgrade for cycle use,
- * surfacing

Item 35: Sandbach Service Station (north&southbound), service roads

- * allow access for cycles by modifying the 'no entry/one way' signs at Newcastle Road

Item 36: Sandbach Heath, The Hill/Newcastle Road/A533, up to service roads for motorway service station

- * speed reduction to 30 mph

Item 37: Sandbach FP 27; Wheelock Hall Farm – access for employees of the farm shop and farm workers

A534/Haslington bypass, between Wheelock roundabout and Elton Road

- * Option 1: extending FP27 through farm driveways and emerging onto A534. Upgrading to cycleway
- * Option 2: building around 300 metres of cycle way along A534 between Wheelock roundabout and Elton Lane

Objective 5: Supporting access to education and employment sites

12. Are there any other options under this objective that we could look into that have not been identified?

Sandbach town cycling plan:

Item 5: Elworth, Elton Crossings Road, crossing Salt Line Way to (the old part of) Moston Road (access from 'poets estate' to Elworth CoE Primary School and the church

- * crossing for cyclists, i.e. dropped kerbs in 'desire line'; removal/realignment of bollards

Item 6: Ettiley Heath, Sandbach, FP 29, from Elton Road to Masefield Way (access to Wheelock Hall Primary School via shared footway for pedestrians and cyclists on Hind Heath Road)

- * upgrade for cycle use

6.3

- * widening where possible

Item 8: Elworth, Lawton Grange Way to Elworth Hall Primary School and co-op shop

- * widening of existing footpath
- * integrating with 5 cul-de-sacs

Item 15: Field Drive (access to primary and secondary school on Crewe Road)

- * signposting through route from Park Lane via Field Drive to Crewe Road
- * upgrade of connection Field Drive/Crewe Road

Item 16: Sandbach, Offley Road to Bradwall Road, Sandbach FP 6, via Sandbach Rugby Union Club

- * upgrade for cycle use,
- * partly surfacing
- * seeking connection through Rugby Club

Item 17: Offley Road:

- * provide cycling provision along Offley Road from the school to a safe place to cross Congleton Road

Not yet mentioned on the Sandbach town cycling plan: Bramall Close to Congleton Road (access to Offley Road Primary School)

- * access for cyclists along the short footpath

Item 29: Capricorn development, link to Church Lane via FP 14 (access to St John Primary School)

- * extend proposed pedestrian connection to cyclists too

Objective 6: Strengthening the transport network to accommodate development such as the 'Capricorn' Local Plan site

14. Are there any other options under this objective that we could look into that have not been identified?

Sandbach town cycling plan:

Item 28: Sandbach Heath, Hawthorne Drive to Capricorn development

* connection between the two developments seems part of planning condition (perhaps this has been realised in the meantime)

Item 29: Capricorn development, link to Church Lane via FP 14

* extend proposed pedestrian connection to cyclists too

Item 30: Capricorn development to Wrights Lane and Willow Drive. Further connections within Capricorn as in Appendix of Town Cycling Plan

* extend proposed pedestrian connections to cyclists too

Dear Planning,

Please find my comments for the above application

1. New footpath/cycle route to the western side of the development

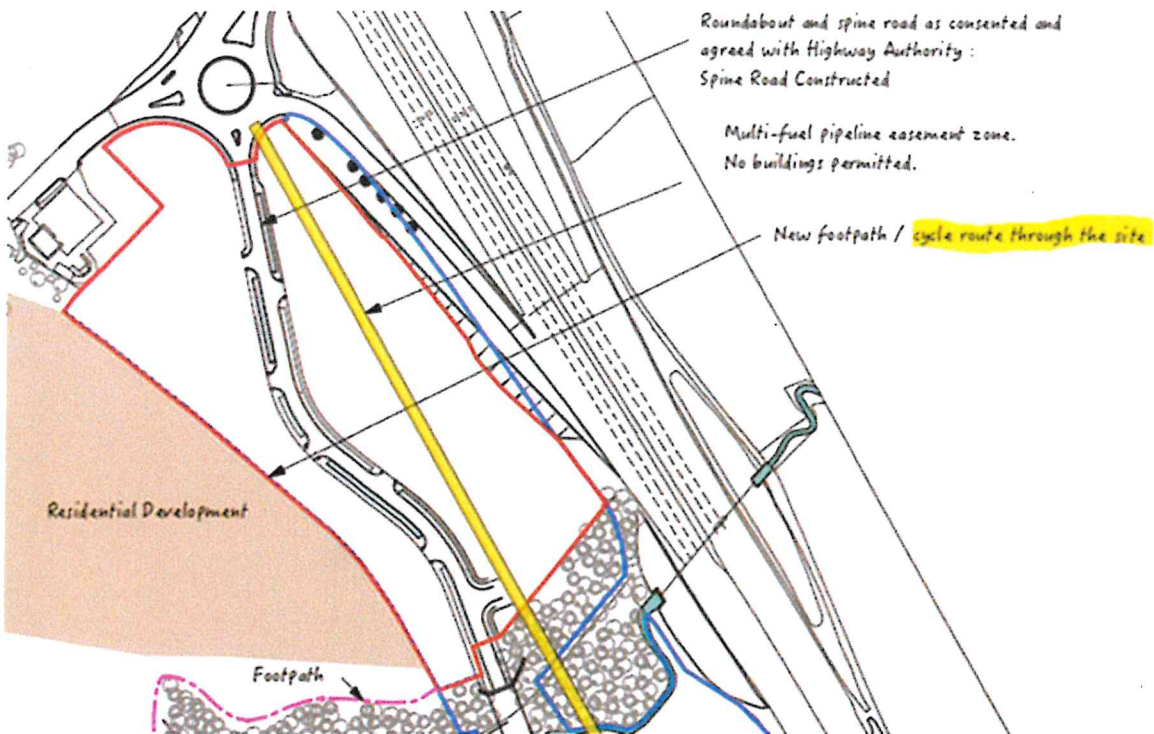

I would be interested in further details as this is a 'full planning' application. the planning Statement mentions 'A new shared footpath and cycle line (sic) is proposed which will connect to the existing Public Right of Way to the north (Public Footpath Sandbach No.11) and new footpath which forms part of the residential development to the south.'

- FP 11 I believe lies to the west
- how does it connect at the north-western end? I would welcome continuation for cycling via FP11 across Old Mill road to Alderley close or Swettenham Close. This is an aspiration of the Sandbach Town Cycling Plan, item 27, page 14
- how does it connect at the south-eastern ends where it could join up with FP14 to Church Lane? This is an aspiration of the Sandbach Town Cycling Plan, appendix 1, Capricorn, Section E, - recommendations, paragraphs 2 and 3.
- how does it connect to the properties on the south west side? I would like to see connectivity for cycling throughout the sites.
- the surface for the cycle route preferably be tarmac
- minimum, effective width to be 3metres, unaffected by street furniture
- the legal status for cycling should be clarified
- signposting to indicate that cycling is allowed (see also Cheshire East Cycling Strategy, Cycle-Proofing Toolkit, Submission and Consultation Stage: 'Are the proposed pedestrian and cycle connections legible and include signage between the site and local facilities?')
- I suggest to add all the above details as planning conditions.

2. Cycle parking

6.4

The withdrawn application 19/4978C mentioned good cycle parking at all buildings. the relevant details are not present with this new application but I assume they will be similar.

The Sheffield type racks should be installed as per specification in the local authority's design guide.

Figure DG19 Sheffield stand - inset 'toast rack' type. Sheffield stands can accommodate two cycles provided that stands are placed 1m apart and at least 500mm from any wall.

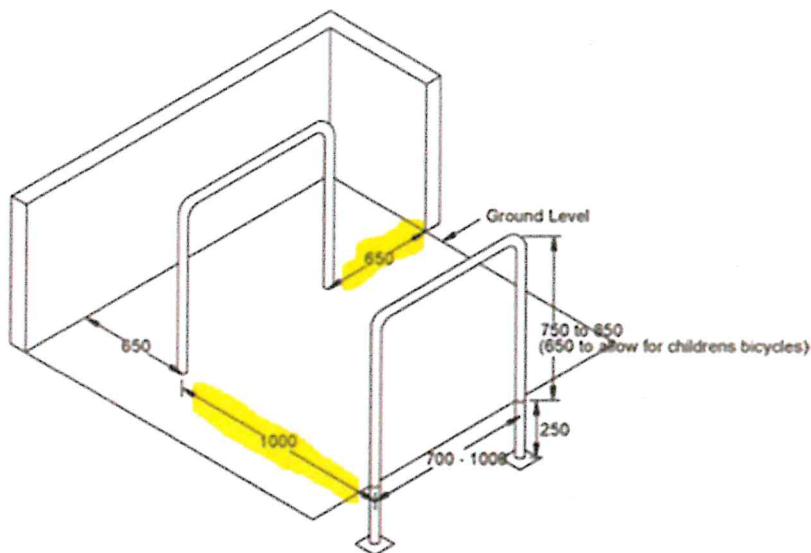

Regards

Matthias Bunte

Cycling UK, Sandbach